

IsoBlock I-ST-4c

4-Channel Shunt Based Current Measuring Module

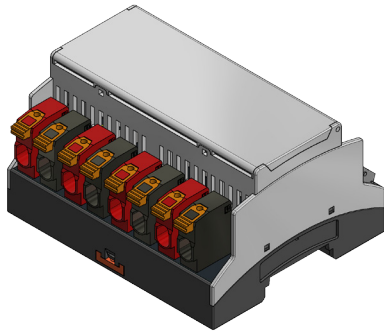

OVERVIEW

The IsoBlock I-ST is a 4 (four) channel module designed for high-quality isolated current measurements in the range from 1mA to 30 Amperes. The IsoBlock Current-ST module provides 1500V primary-to-secondary isolation, which allows users to monitor a miscellaneous of currents at different potentials.

The IsoBlock Current-ST uses isolated shunt methodology to measure the current flowing through the input conductor. The input current is then obtained by amplifying the 50mV voltage drop across the shunt. This is followed by an anti-aliasing filter and a conditioning stage to output a $\pm 10V$ signal.

The compact form factor of the IsoBlock Current-ST module allows users to setup high channel density monitoring systems.

SPECIFICATION

Electrical	
Accuracy (percentage of reading)	$\pm(0.2\% \text{ of reading} + 0.005\% \text{ range})$ or $\pm(0.1\% \text{ of reading} + 0.005\% \text{ range})$
Max total phase shift at 60Hz	$< 0.05^\circ$
Max Input delay (100kHz versions)	$< 2.8 \mu\text{s}$
Isolation voltage from primary to secondary	$> \pm 1500 \text{ V}$
Withstanding common mode surge voltage	$\pm 5000 \text{ V}$
Withstanding differential mode surge voltage	$\pm 2500 \text{ V}$
Thermal drift gain	$< \pm 0.01\% / ^\circ\text{C}$
Mechanical	
Mounting Type	DIN Rail
Connectivity (Connector for power in and signal out to/from the sensor)	Spring Cage connector
Outer Dimensions	3.9" x 3.5" x 2.5"
Channels	4 channels

Performance	
Input ranges	$\pm 1\text{mA}, \pm 2\text{mA}, \pm 3\text{mA}, \pm 5\text{mA}, \pm 10\text{mA}, \pm 20\text{mA}, \pm 30\text{mA}, \pm 50\text{mA}, \pm 100\text{mA}, \pm 200\text{mA}, \pm 300\text{mA}, \pm 500\text{mA}, \pm 1\text{A}, \pm 2\text{A}, \pm 3, \pm 4\text{A}, \pm 5\text{A}, \pm 10\text{A}, \pm 20\text{A}, \pm 30\text{A}, \text{Custom}$
Bandwidth (-3dB point)	100kHz (custom option)
Input-Output non-linearity	$< \pm 0.04\%$
Integrated channel noise (Referenced to output)	$< 1.2 \text{ mV}$
Output voltage	$\pm 10\text{V} (\pm 5\text{V custom})$
Gain temperature drift	$\pm 50 \text{ ppm}/^\circ\text{C}$
Common mode rejection at 60Hz	112 dB
Power Supply Voltage *	12V to 28 V
Output type	Differential pair
Output Offset Voltage (Referenced to output)	$2\sigma < \pm 500 \mu\text{V} \text{ (typical)}$ $4\sigma < \pm 1 \text{ mV} \text{ (limit)}$
Voltage drop at input	$< 50\text{mV}$
Insulation impedance	$> 10 \text{ G}\Omega \parallel 2\text{pF}$
Output impedance	100 Ω
Environmental	
Operating temperature	$- 25 \text{ to } 70 \text{ } ^\circ\text{C}$
Storage temperature	$- 40 \text{ to } 80 \text{ } ^\circ\text{C}$

HARDWARE DESCRIPTION

The IsoBlock I-ST module is designed to measure and isolate currents found in industrial environments. The end result is a signal ready to connect to any data acquisition system, while galvanically isolating the source from it.

Each channel of the IsoBlock module has a galvanic isolation from the input to the output that can eliminate large common mode voltages. In addition to that, each channel also has a protection stage at the input that guards it from surges.

Following the input surge protection stage, there is an amplification stage that brings the input signal to a $\pm 10V$ range. This signal is modulated into a magnetic field, and then transferred across a galvanic barrier. A demodulating stage recovers the original signal, followed by an anti-aliasing filter and a conditioning stage to output a $\pm 10V$ differential pair. The figure below shows a block diagram of the process described above.

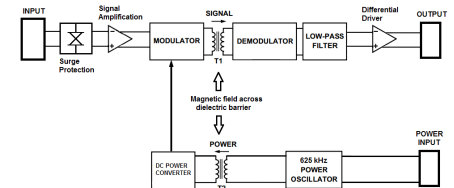

IsoBlock I-ST channel block diagram.

MERCHANDISE DIMENSIONS

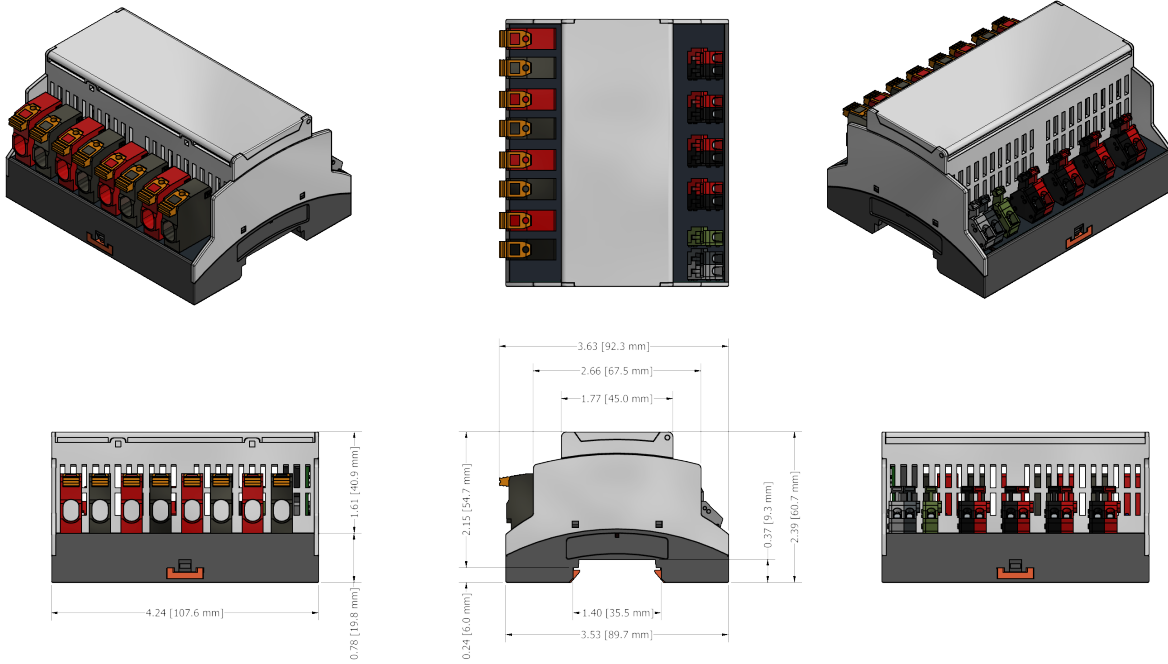

HARDWARE CONFIGURATION

A. Connect external power source to power the unit. For proper functioning the power supply should provide a voltage between 12V and 28V with at least 4W continuous and three times surge during module start-up. (10ms)

B. Securely connect wire in the 20-6 AWG range between the source of measurement and an available IsoBlock's input spring cage terminal.

C. Securely connect one end of a twisted pair to the output terminals, and the other end to the inputs of your data acquisition unit

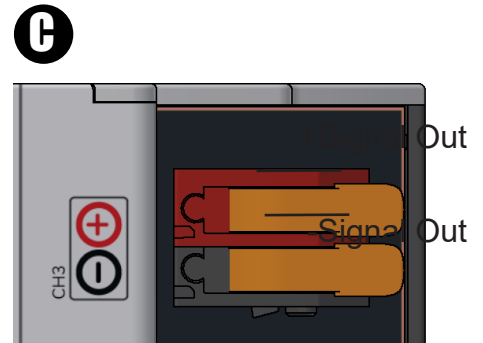
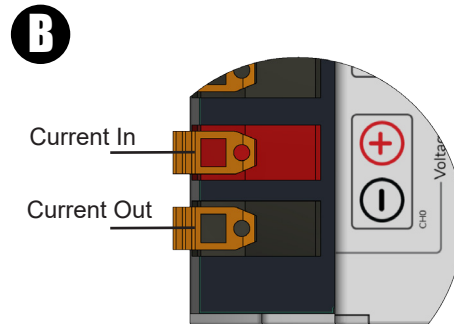
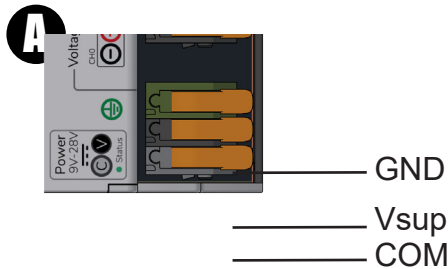

Standards and Certifications

- CE



Warning

THIS SENSOR IS NOT A SAFETY DEVICE AND IS NOT INTENDED TO BE USED AS A SAFETY DEVICE. This sensor is designed only to detect and read certain data in an electronic manner and perform no use apart from that, specifically no safety-related use. This sensor product does not include self-checking redundant circuitry, and the failure of this sensor product could cause either an energized or de-energized output condition, which could result in death, serious bodily injury, or property damage.